



Donaldson
FILTRATION SOLUTIONS

HEAT REGENERATED ADSORPTION DRYERS



Clean Adsorption Drying

The Importance of dry and clean Compressed Air

In nearly all areas of the industry compressed air is one of the indispensable working medias. The application as working, conveying, measuring, control and regulating air is just as self-evident as the application in the process technology. The atmospheric inlet air of the compressor contains harmful substances and impurities. Moisture in the form of vapour is condensed out into the compressed air network. This causes expensive damages and a loss in quality. Therefore processing concepts consisting of filtration and drying are an integral part of every compressed air application. The drying method is determined by the application. Where very low

residual moisture is a requirement respectively for pressure dewpoints below 0 °C, adsorption drying is applied.

System Construction from a Single Source

Donaldson plans, designs and manufactures complete solutions that are tailored to individual customer's needs. Due to the close link between technical design and manufacture, customized systems arise from a single source for the benefit of customers. Particular emphasis is placed on the ease of maintenance, by incorporating accessibility of all wearing parts in the design.

Choice of Heat Regenerated Adsorption Dryers

Adsorption Dryer	HRE	HRG+	HRS	HRS-L
Climate Conditions	<ul style="list-style-type: none"> ■ Moderate ■ Subtropical ■ Tropical 	<ul style="list-style-type: none"> ■ Moderate 	<ul style="list-style-type: none"> ■ Moderate 	<ul style="list-style-type: none"> ■ Moderate ■ Subtropical ■ Tropical
Energy-savings		Zero Purge	Zero Purge	Zero Purge
Regeneration	<ul style="list-style-type: none"> • Desorption in counter current flow to the adsorption direction with externally heated blower air • Cooling in counter current flow with partial flow (2 %) of the already dried compressed air 	<ul style="list-style-type: none"> • Desorption in co-current flow to the adsorption direction with externally heated blower air • Cooling by blower air 	<ul style="list-style-type: none"> • Desorption in counter current flow to the adsorption direction with externally heated blower air • Cooling by blower air 	<ul style="list-style-type: none"> • Desorption in counter current flow to the adsorption direction with externally heated blower air • Closed-loop cycle (Loop Version)

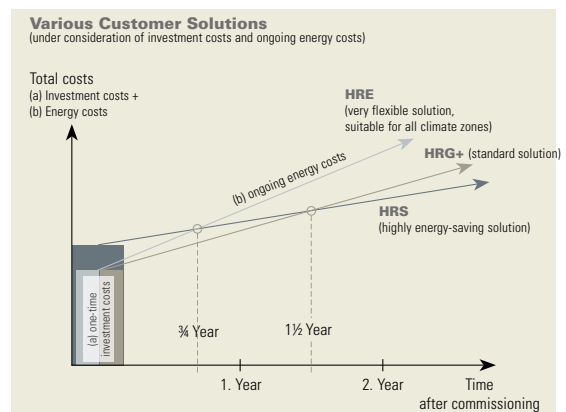
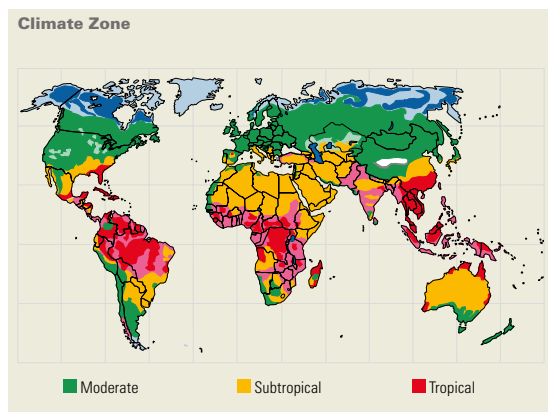

Adsorption Dryer Type HRE and HRG+

Heat Regenerated Adsorption Dryers HRE, HRG+, HRS, HRS-L

The externally heated adsorption dryers of the HRE, HRG+, HRS, and HRS-L models offer versatile pos-

sibilities for variation. The standard program includes system sizes of 375 m³ / h to 13,600 m³ / h for pressure dewpoints down to -70 °C.

Adsorption Dryer HRE

As with all externally heated adsorption dryers the desorption of the moisture adsorbed in the desiccant of the HRE models takes place with the heated blower air stream. The cooling of the desiccant is conducted with partial flow of the already dried compressed air. Because the cooling process is independent of the ambient conditions the HRE models can be used worldwide.

Adsorption Dryer HRG+

The HRG+ models, designed according to the co-current concept, also belong to the family of blower air regenerated adsorption dryers. The ambient air drawn in by the blower cools the desiccant that was heated during the desorption phase. Thus, compressed air is not used during the desorption or cooling phase.

Features and Benefits:

- All Climate Zones
- Low Investment Costs
- Easy Maintenance



Type HRE Size 2750

Features and Benefits:

- Energy-saving (Zero Purge)
- Low Investment Costs
- Easy Maintenance



Type HRS Size 6000

Adsorption Dryer Type HRS

Adsorption Dryer HRS

The desorption and cooling in the HRS system variation is also accomplished with the ambient air drawn in by the blower. Compressed air will not be used during the desorption or the cooling phase. Since the desorption occurs in counter current flow, a low energy consumption is required. The HRS is therefore the most energy efficient option.

Features and Benefits:

- Energy-saving (Zero Purge, low desorption temperature)
- Low Operating Costs
- Easy Maintenance



Type HRS Size 2750

Energy Saving
(Zero Purge)

Pressure-Vacuum-Regeneration

Adsorption Phase: For units of the HRS the moisture containing compressed air flows via the inlet fitting through the desiccant bed. While passing the desiccant bed the water vapour is adsorbed by the hygroscopic adsorbent. The dried compressed air is now discharged into the compressed air network.

Desorption Phase without consuming Compressed Air:

Before starting the regeneration, the adsorber to be regenerated is gently depressurized. Desorption takes place in counter current flow to the adsorption direction from top to bottom with externally heated blower air. The temperature increase due to the compression has a positive effect on the energy requirement of the downstream heater. The heater heats up the blower air to the required desorption temperature. The blower air flows in counter current into the adsorber to be desorbed and evaporates the water contained in the desiccant.

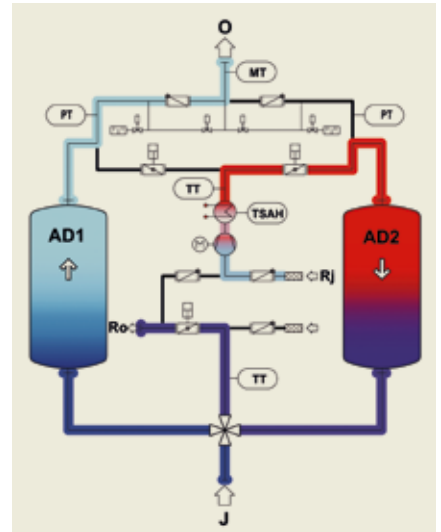

Cooling Phase without consuming Compressed Air:

Up to dryer sizes 2750 the direction of rotation of the blower is switched for the cooling phase so that the ambient air is drawn through the desiccant. The cool ambient air takes up the heat from the desiccant and it is conveyed to the atmosphere. The vacuum that occurs during the suction operation causes the desorption temperature to drop and thus a post-desorption. The residual loading in the desiccant is reduced. A better quality is achieved with the same energy in put, i.e. energy can be saved while maintaining the same quality.

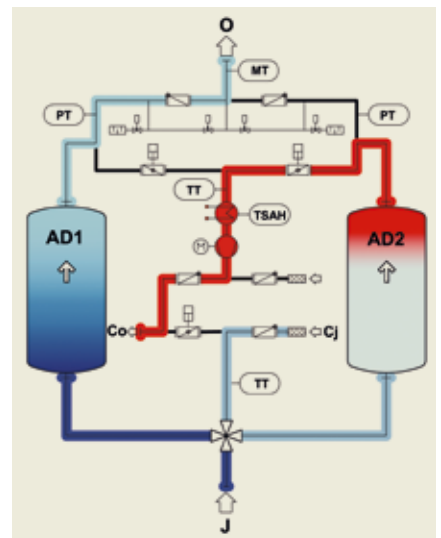

Tailormade System Solutions

Adsorption Dryer HRS-L

Based on the standard HRS models, the HRS-L version is designed for processing requirements at tropical and subtropical ambient conditions. These conditions do not allow for cooling with fresh air. The characteristic feature of the HRS-L models is a closed loop cooling (Loop-Version). A water-cooled heat exchanger cools the air stream heated by the desiccant. From there the cooling air is led back to the inlet port of the blower. Worldwide for all climate zones this version offers a pressure dewpoint of $-70\text{ }^{\circ}\text{C}$.

Tailored Customer Concepts

In decades of close collaboration with our customers, we have built expertise in virtually all areas of industrial production. Donaldson therefore meets exceptional and specific customer requirements with tailored and sophisticated solution concepts.

Beyond the individual concepts, we also provide the respective services for each application.

Features and Benefits:

- Worldwide applicable
- Energy-saving (Zero Purge)
- Low Operating Costs
- Easy Maintenance
- Pressure dewpoint up to $-70\text{ }^{\circ}\text{C}$



Energy Saving
(Zero Purge)

Type HRS-L Size 2750

Type HRE 25000 S

Molecular Sieve Adsorber Station (PPU) HRE 25000 for humidity and CO_2 removal from compressed air for air separation. The highest requirements are met:

- Dewpoint better than $-90\text{ }^{\circ}\text{C}$
- $\text{CO}_2 < 1\text{ ppm}$

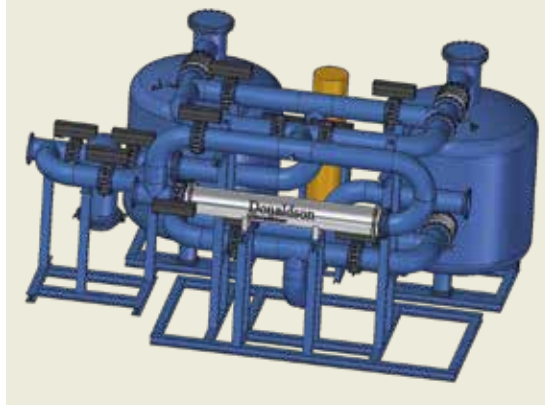

Trendsetting Control Engineering

Touch Panel with a high operational Comfort

All heat regenerated adsorption dryers in the series HRE, HRG+, HRS and HRS-L as well as all tailored systems solutions are equipped with a Touch Panel System as standard.

The basic setting of the multilingual panel shows the present operating state as well as the relevant operating parameters, such as pressure, temperatures and dew point. By touching the corresponding control panel, further information can be recalled. The main control menu can also be accessed via this user-friendly interface.

Authorized staff may adapt the operating parameters to the ambient conditions and operating requirements. The service technician also parametrizes the plant via the touch panel and can access for example, additional diagnosis information.

Outstanding Features:

- Human Machine User Interface control with self-explanatory menus
- Large colour display
- Display of all operating parameters in the main menu
- Clear and concise display of the current operating condition
- Easy to optimize the operating parameters to the local conditions
- Multilingual (English, German, French as a standard), other languages optional

State-of-the-Art Technology!



The standard and multi-language touch panel for adsorption dryers provides an excellent ease of operation. All information is accessed by touching the buttons.

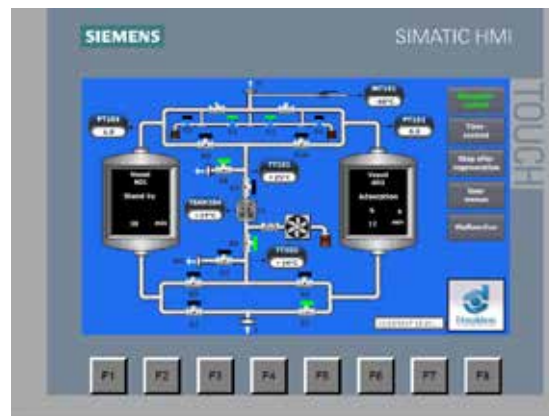

The system overview shows the main operational data such as pressure, temperature, cycle of the tanks (adsorption, desorption, cooling, standby).

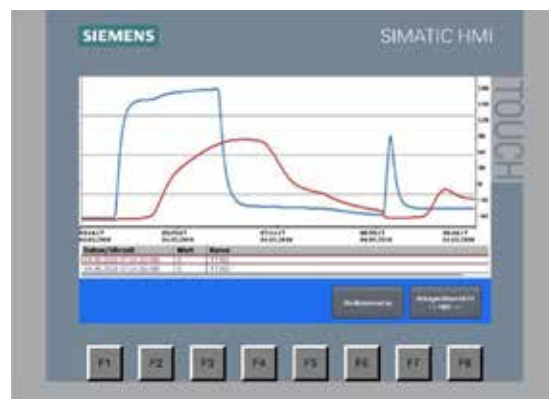

The temperature cycles can be clearly displayed in a diagram. The exact values are listed for the intersections with the black line (movable).

Innovative Concepts for Biogas/ Biomethane Treatment

Future-oriented and economical Biogas/ Biomethane Concepts

An intelligent supply and an economical use of energy are key challenges of today. An important contribution to our climate protection and counteract to fossil materials is the use of renewable primary materials. Main objective of the European Union is to increase the part of renewable energy up to 20 % until 2020. (EU Guideline 2009/28/EG). Donaldson is meeting this challenge as well and introduces innovative and tailor-made dryer concepts as a part of the biogas treatments.



Biogas Dryer Type ARBG

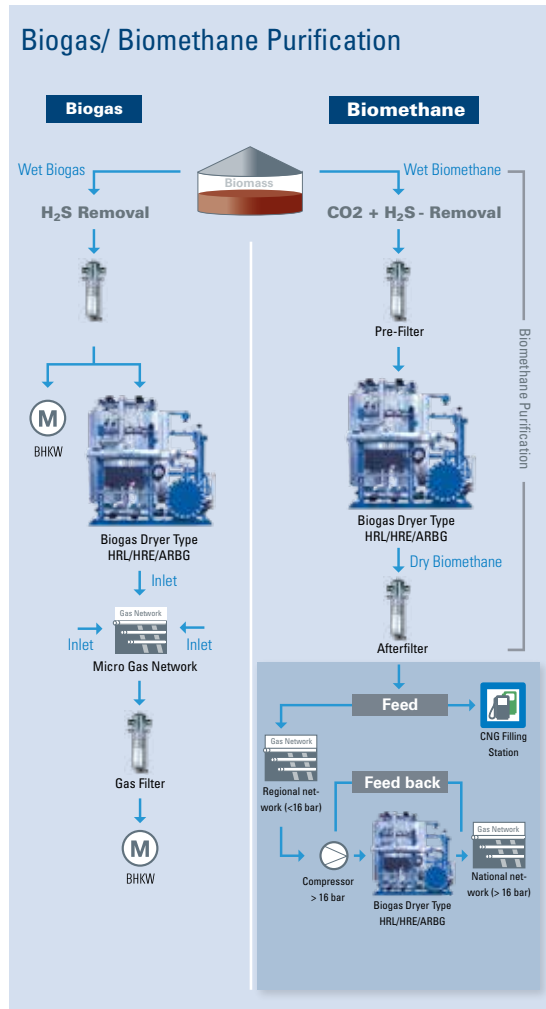

Biogas Drying Solutions

Dryer Concepts	ARBG	HRL	HRE
Features	ZERO LOSS System Regeneration with dry gas and gas return to the inlet of the drying unit	ZERO LOSS System Regeneration in a closed circuit	PURGE LOSS System Regeneration with dry gas, respectively from external delivery. By refeeding into the compressor, the drying is integrated in the process and becomes a ZERO LOSS System.
Operating Temperature	5 – 30 °C	5 – 20 °C	5 – 30 °C
Operating Pressure	5 – 40 bar	150 – 400 mbar	5 – 40 bar
Residual Water Content	< 50 mg/Nm ³	< 50 mg/Nm ³	< 50 mg/Nm ³
Volume Flow	100 – 6000 Nm ³ /h	100 – 4000 Nm ³ /h	100 – 6000 Nm ³ /h
Accessories	Tubular bundle heat exchanger for pre- and aftercooling, Demister, Cyclone, Coalescence Filter, Particle Filter, Condensate Drain		

Everything from a single Source

Service with the highest Standards

Our service is always nearby. With our technical service and support network throughout Europe, we can routinely service your production systems as well as provide on-site support whenever needed.



With one of Donaldson's service centers you receive quick and cost-effective competent services for all filtration applications from one source.

Donaldson Adsorption Dryers stand for:

- Reliability
- Efficiency
- High reserve capacity
- Easy maintenance
- Easy operation
- Models with no loss of compressed air

Donaldson[®]
Ultrafilter

Compressed Air Filtration · Filters for Sterile Air, Steam and Liquids · Refrigerant Drying · Adsorption Drying · Condensate Drains · Condensate Purification Systems · Process Air and Gas Processing



Donaldson[®]
FILTRATION SOLUTIONS

Total Filtration Management

Donaldson offers a wide variety of solutions to reduce your energy costs, improve your productivity, guarantee production quality and help protect the environment.

Total Filtration Service

A comprehensive range of services keeps your production at peak performance and at the lowest total cost of ownership.

Please contact us:

Donaldson Europe B.V.B.A.
Research Park Building No. 1303 · Interleuvenlaan 1
B-3001 Leuven · Belgium
Phone +32(0)16 38 38 11 · Fax +32(0)16 40 00 77
CAP-europe@donaldson.com · www.donaldson.com